

Application

The centrifugal submersible sewage pumps MultiStream are suitable for handling effluent or sewage in municipal and industrial pumping stations as well as in surface water drainage applications. The smaller types are also used very successfully as portable units to deal with emergency situations.

- The sewage pumps **UAK** are suitable für handling sewage water.
- In hazardous locations **explosion-proof sewage pumps UFK** have to be used.

The adjustable axial gap of the MultiStream-pump makes it possible to re-optimize the efficiency in case of abrasion by adjusting only one single screw. This can be done very cost-effective when the maintenance is carried out and the pump keeps its optimum performance on a long-term basis.

MultiStream-pumps are recommendet for:

- effluent which contains fibrous matter
- effluent which contains solids
- mixed water
- raw effluent
- raw sludge
- rainwater

Technical data

Pump

Vertical, single-stage, submersible, pump case with horizontal discharge, single channel impeller and short shaft extension. This provides a longer service life for the ball bearings and the mechanical seal.

Bearings

Common shaft for pump and motor, deep groove and inclined ball bearings, grease-packed.

Seal

Silicon carbide mechanical seal independent of sense of rotation, oil chamber and artificial carbon mechanical seal or rather SiC mechanical seal (or duplex rotary shaft seal up to size 35) as secondary seal, safe to run dry.

Motor

Submersible, enclosure IP68, activation through special purpose plug or control unit, protected by winding thermostats, UFK types tested by PTB (German tech. inspection authority), type of protection $\text{Ex II 2 G Ex d IIB T4}$.

Materials

Pump, motor case and impeller in GG grey cast iron (single channel impeller with $n = 2800 \text{ min}^{-1}$ from size 55/2 in spheroidal graphite iron GGG), corrosion protected shaft (no contact with pumped liquid), flexible rubber sheathed cable.

Installation

Install pump vertically with guide rail system or pump base. Flange coupling according to DIN, coupling size B or hose tail bend up to 3" possible.

Scope of supply

Pump acc. to EN 12050 with 10 m cable without plug, without pump base:

- a) as sewage pump UAK
- b) as explosion-proof sewage pump UFK



Types of operation: Up to 40°C medium temperature
 UAK/UFK Motor submerged: continuous operation S1
 UAK/UFK Motor not submerged intermittent operation S3
 (e.g. 15% = 1.5 min operation and 8.5 min pause)

- Adjustable single-channel impeller
- Connection alternatively PN 6 or PN 10
- Safe to run dry
- Controllable oil chamber
- Plug type cable connection
(UAK/UFK 10...-100...)
- SiC mechanical seal independent of sense of rotation
- Moisture sealed cable inlet
- Built-in motor protection



DN 65 **n = 2800 min⁻¹**

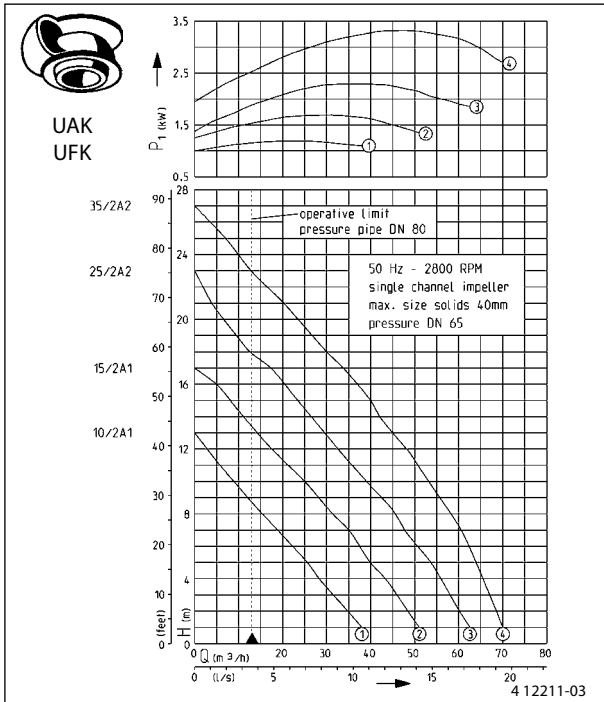

The minimum flow rate in the pressure pipe of $v = 0,7$ m/s is marked in the Q-H-diagram (operative limit). Pump performance is subject to ISO 9906 tolerances

Performance

Type UAK/UFK	1	2	3	4	5	6	7	8	9	10	12	14	16	18	20	22	24	H [m]	
10/2 A1	38	35	32	29	26	22	19	15	12	9									Flow rate Q [m ³ /h]
15/2 A1	50	48	46	43	40	37	35	32	28	25	18	11	5						
25/2 A2	62	60	58	56	54	51	48	46	42	39	33	27	20	13	7				
35/2 A2	70	69	67	66	64	63	61	58	56	53	48	43	37	30	24	16	10		

Technical data

Type UAK/UFK	Voltage (50 Hz) Volt	Max. Motor Rating (kW) P ₁ P ₂	S3-% Operation Emerged Motor	Max. Current Ampere	RPM min ⁻¹	Cable (10 m) H07RN-F-	Fuse min.	Discharge branch PN 6/10	Max. Solid Size (mm)	Weight ca. kg
10/2 A1	3/PE~230/400	1.30 1.10	60	4.6/2.7	2943	° 6 G 1.5	10 A	DN 65	40	41 kg
15/2 A1	3/PE~230/400	1.80 1.50	50	5.7/3.3	2910	° 6 G 1.5	10 A	DN 65	40	42 kg
25/2 A2	3/PE~230/400	2.60 2.10	40	7.6/4.4	2860	° 6 G 1.5	10 A	DN 65	40	48 kg
35/2 A2	3/PE~230/400	3.70 3.04	40	11.5/6.6	2895	° 6 G 1.5	10 A	DN 65	40	52 kg

* plug-in

DN 80 / DN 100 **n = 2800 min⁻¹**

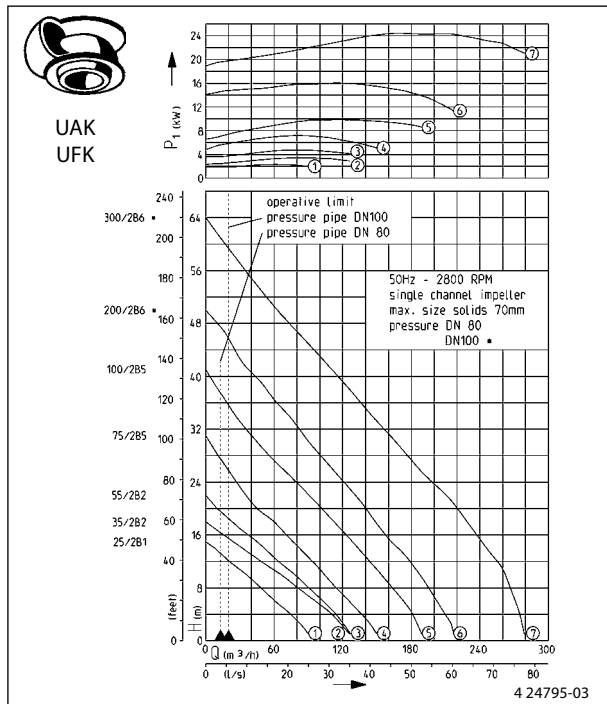

The minimum flow rate in the pressure pipe of $v = 0,7$ m/s is marked in the Q-H-diagram (operative limit).

DN 80 / DN 100 **n = 1400 min⁻¹**

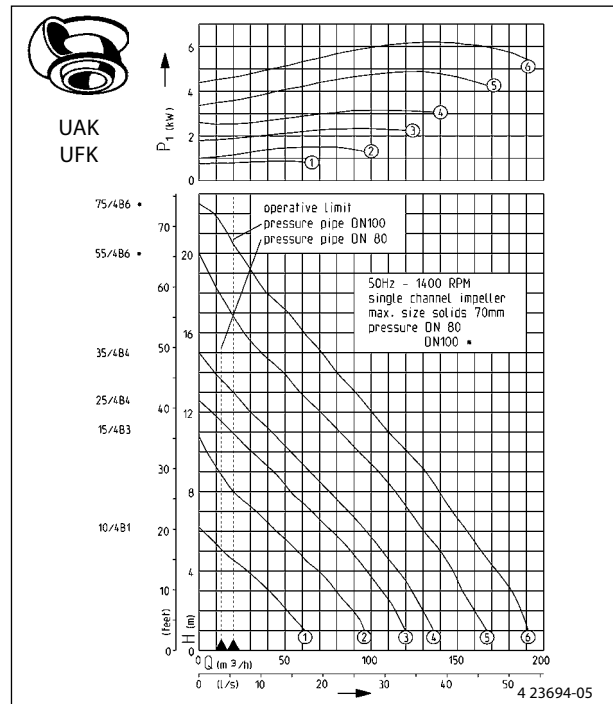

Pump performance is subject to ISO 9906 tolerances

Performance

Type UAK/UFK	1	3	6	9	12	15	18	21	24	27	30	33	36	40	43	46	50	53	56	60	H [m]	
25/2 B1	91	80	62	43	21																	Flow rate Q [m³/h]
35/2 B2	126	117	97	73	49	23																
55/2 B2	127	118	103	85	65	44	24	6														
75/2 B5	150	142	126	110	93	77	59	42	27	15												
100/2 B5	190	184	173	159	144	129	113	97	78	63	46	32	18									
200/2 B6	217	215	204	191	177	162	149	136	120	104	91	77	62	43	28	19						
300/2 B6	280	277	270	263	254	242	229	216	199	183	167	152	136	113	100	84	63	49	34	17		
Type UAK/UFK	1	2	3	4	5	6	7	8	9	10	11	12	14	15	16	17	18	20	H [m]			
10/4 B1	60	51	40	28	14	3																Flow rate Q [m³/h]
15/4 B3	98	89	79	69	57	45	33	20	12	5												
25/4 B4	120	114	106	97	87	77	65	53	43	31	19											
35/4 B4	132	125	119	112	104	95	85	74	64	53	43	30	10									
55/4 B6	167	160	154	147	140	132	123	114	104	93	82	72	49	39	28	19	12					
75/4 B6	191	188	181	173	163	157	149	141	131	122	113	104	82	73	62	52	41	24				

Technical Data

Type	Voltage (50 Hz) Volt	Max. Motor Rating (kW)		S3-% Operation Emerged Motor	Max. Current Ampere	RPM min ⁻¹	Cable (10 m) H07RN-F-	Fuse min.	Discharge branch PN 6/10	Max. Solid Size (mm)	Weight ca. kg
		P ₁	P ₂								
25/2 B1	3/PE~230/400	2.60	2.10	40	7.6/ 4.4	2860	° 6 G 1.5	10 A	DN 80	70	45 kg
35/2 B2	3/PE~230/400	3.70	3.04	40	11.5/ 6.6	2895	° 6 G 1.5	10 A	DN 80	70	55 kg
55/2 B2	3/PE~400/690	5.20	4.45	40	8.7/ 5.0	2910	° 10 G 2.5	*16 A	DN 80	70	88 kg
75/2 B5	3/PE~400/690	7.70	6.60	30	13.2/ 7.7	2925	° 10 G 2.5	*20 A	DN 80	70	98 kg
100/2 B5	3/PE~400/690	10.50	9.20	30	17.6/10.2	2920	° 10 G 2.5	*25 A	DN 80	70	121 kg
200/2 B6	3/PE~400/690	17.30	15.40	45	28.8/16.7	2940	10 G 2.5	*35 A	DN 100	70	212 kg
300/2 B6	3/PE~400/690	27.00	24.45	35	43.0/24.7	2950	7G6+3x1	*50 A	DN 100	70	257 kg
10/4 B1	3/PE~230/400	0.95	0.73	50	4.2/ 2.4	1466	° 6 G 1.5	10 A	DN 80	70	45 kg
15/4 B3	3/PE~230/400	1.80	1.40	40	5.9/ 3.4	1426	° 6 G 1.5	10 A	DN 80	70	50 kg
25/4 B4	3/PE~230/400	2.70	2.04	25	7.9/ 4.6	1376	° 6 G 1.5	10 A	DN 80	70	59 kg
35/4 B4	3/PE~230/400	3.50	2.65	25	12.0/ 6.9	1424	° 6 G 1.5	10 A	DN 80	70	62 kg
55/4 B6	3/PE~400/690	5.80	4.65	20	10.2/ 5.9	1430	° 10 G 2.5	*16 A	DN 100	70	111 kg
75/4 B6	3/PE~400/690	7.20	5.90	25	12.8/ 7.4	1432	° 10 G 2.5	*20 A	DN 100	70	116 kg

° plug-in

* Value for Y/Δ-starting

DN 100 **n = 1400 min⁻¹**

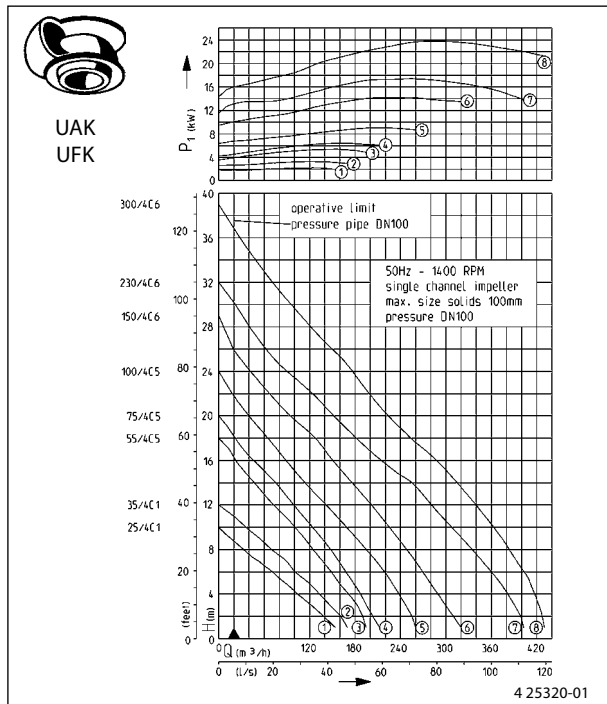

The minimum flow rate in the pressure pipe of v = 0,7 m/s is marked in the Q-H-diagram (operative limit).

DN 100 **n = 1400 min⁻¹**

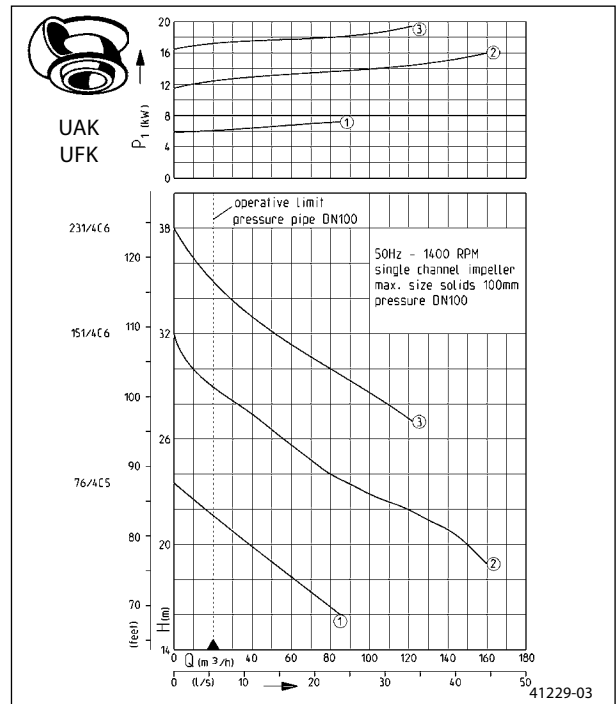

Pump performance is subject to ISO 9906 tolerances

Performance

Type UAK/UFK	1	3	5	7	9	12	14	16	18	20	23	24	26	27	28	29	30	31	34	37	38	H [m]
25/4 C1	154	122	87	51	16																	Flow rate Q [m³/h]
35/4 C1	170	146	119	89	54																	
55/4 C5	198	181	160	136	112	74	45	22														
75/4 C5	212	195	179	160	138	99	74	46	22													
100/4 C5	260	247	228	207	182	142	114	89	65	40	9											
150/4 C6	320	302	280	260	236	202	177	152	126	96	54	43	20	14	8							
230/4 C6	405	390	372	344	320	283	255	218	182	155	110	91	62	51	40	32	22	8				
300/4 C6	430	421	411	393	374	341	315	289	254	225	188	176	151	135	117	107	95	83	47	19	10	
Typ UAK/UFK	1	3	5	7	9	12	14	16	18	20	23	24	26	27	28	29	30	31	34	37	38	H [m]
76/4 C5								85	62	38	9											Flow rate Q [m³/h]
151/4 C6										149	101	81	54	44	35	23	10					
231/4 C6													125	111	94	80	68	31				

Technical Data

Type UAK/UFK	Voltage (50 Hz) Volt	Max. Motor Rating (kW)		S3-% Operation Emerged Motor	Max. Current Ampere	RPM min ⁻¹	Cable (10 m) H07RN-F-	Fuse min.	Discharge branch PN 6/10	Max. Solid Size (mm)	Weight ca. kg
		P ₁	P ₂								
25/4 C1	3/PE~230/400	2.40	1.90	30	7.3/ 4.2	1395	° 6 G 1.5	10 A	DN 100	100	63 kg
35/4 C1	3/PE~230/400	3.50	2.65	25	12.0/ 6.9	1424	° 6 G 1.5	10 A	DN 100	100	67 kg
55/4 C5	3/PE~400/690	5.80	4.65	20	10.2/ 5.9	1430	° 10 G 2.5	*16 A	DN 100	100	119 kg
75/4 C5	3/PE~400/690	7.20	5.90	25	12.8/ 7.4	1432	° 10 G 2.5	*20 A	DN 100	100	124 kg
100/4 C5	3/PE~400/690	9.50	7.94	25	17.2/10.0	1444	° 10 G 2.5	*25 A	DN 100	100	138 kg
150/4 C6	3/PE~400/690	15.00	13.20	40	26.7/15.5	1466	10 G 2.5	*35 A	DN 100	100	247 kg
230/4 C6	3/PE~400/690	19.30	17.00	35	34.1/19.8	1460	10 G 2.5	*35 A	DN 100	100	275 kg
300/4 C6	3/PE~400/690	25.50	22.65	25	45.5/26.4	1460	7G6+3x1	*50 A	DN 100	100	296 kg
76/4 C5	3/PE~400/690	8.25	6.70	15	14.2/ 8.2	1409	° 10 G 2.5	*20 A	DN 100	100	124 kg
151/4 C6	3/PE~400/690	17.50	15.30	25	30.6/17.7	1452	10 G 2.5	*35 A	DN 100	100	247 kg
231/4 C6	3/PE~400/690	22.00	19.10	25	37.9/22.0	1446	10 G 2.5	*35 A	DN 100	100	276 kg

° plug-in

* Value for Y/Δ-starting

DN 150 **n = 1400 min⁻¹**

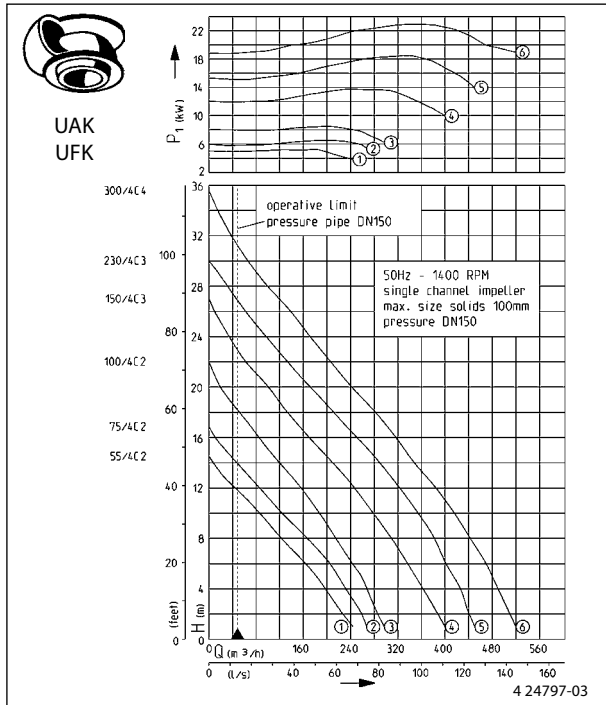

The minimum flow rate in the pressure pipe of $v = 0,7$ m/s is marked in the Q-H-diagram (operative limit).

DN 150 **n = 1400 min⁻¹**

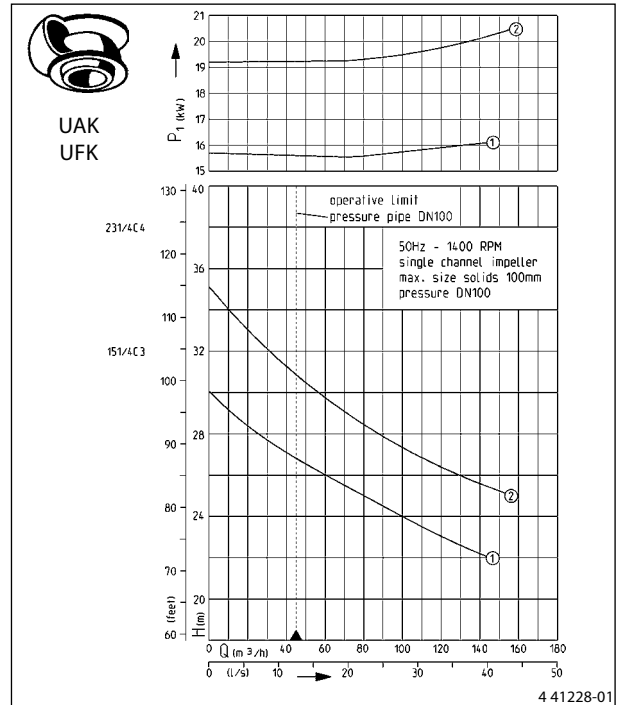

Pump performance is subject to ISO 9906 tolerances

Performance

Type UAK/UFK	1	3	5	7	9	11	13	15	17	19	20	21	24	25	27	29	30	31	33	34	H [m]			
55/4 C2	245	214	184	144	105	62	22															Flow rate Q [m³/h]		
75/4 C2	270	245	216	185	146	105	64	26																
100/4 C2	300	278	258	229	202	167	130	96	65	33	18													
150/4 C3	400	373	349	325	295	263	227	192	150	116	100	81	34	21										
230/4 C3	455	434	415	394	369	338	308	272	231	191	172	153	98	80	45	17								
300/4 C4	520	500	478	455	426	399	364	334	298	263	242	223	172	157	118	83	66	51	26	15				
Type UAK/UFK	1	3	5	7	9	12	14	16	18	20	23	24	26	27	28	29	30	31	34	37	38	H [m]		
151/4 C3											119	98	61	44	28	15							Flow rate Q [m³/h]	
231/4 C4													136	113	92	75	59	43	7					

Technical Data

Type UAK/UFK	Voltage (50 Hz) Volt	Max. Motor Rating (kW)		S3-% Operation Emerged Motor	Max. Current Ampere	RPM min ⁻¹	Cable (10 m) H07RN-F-	Fuse min.	Discharge Branche PN 6/10	Max. Solid Size (mm)	Weight ca. kg
		P ₁	P ₂								
55/4 C2	3/PE~400/690	5.80	4.65	20	10.2/ 5.9	1430	° 10 G 2.5	*16 A	DN 150	100	125 kg
75/4 C2	3/PE~400/690	7.20	5.90	25	12.8/ 7.4	1432	° 10 G 2.5	*20 A	DN 150	100	131 kg
100/4 C2	3/PE~400/690	9.50	7.94	25	17.2/10.0	1444	° 10 G 2.5	*25 A	DN 150	100	149 kg
150/4 C3	3/PE~400/690	15.00	13.20	40	26.7/15.5	1466	10 G 2.5	*35 A	DN 150	100	268 kg
230/4 C3	3/PE~400/690	19.30	17.00	35	34.1/19.8	1460	10 G 2.5	*35 A	DN 150	100	288 kg
300/4 C4	3/PE~400/690	25.50	22.65	25	45.5/26.4	1460	7G6+3x1	*50 A	DN 150	100	308 kg
151/4 C3	3/PE~400/690	17.50	15.30	25	30.6/17.7	1452	10 G 2.5	*35 A	DN 150	100	269 kg
231/4 C4	3/PE~400/690	22.00	19.10	25	37.9/22.0	1446	10 G 2.5	*35 A	DN 150	100	290 kg

* plug-in

* Value for Y/Δ-starting

DN 200 **n = 1400 min⁻¹**

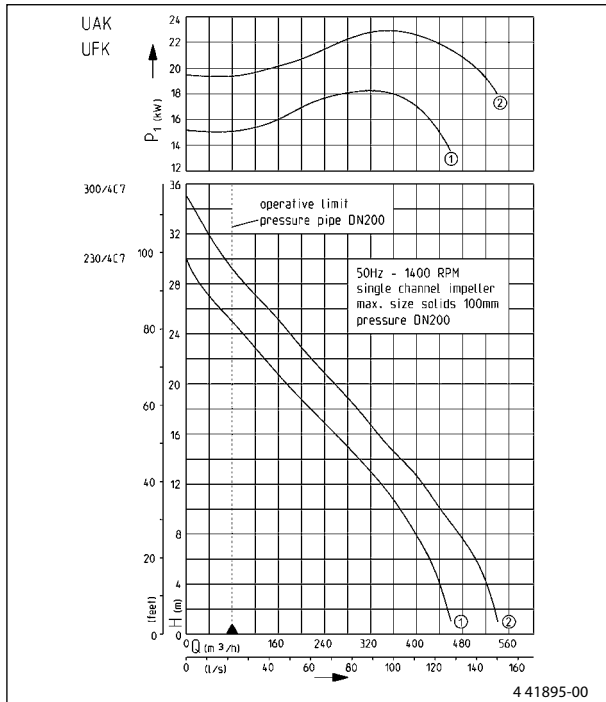

The minimum flow rate in the pressure pipe of $v = 0,7 \text{ m/s}$ is marked in the Q-H-diagram (operative limit).

Performance

Type	1	3	5	7	9	11	13	15	17	19	20	21	24	25	27	29	30	31	33	34	H [m]	
UAK/UFK	460	443	429	409	387	358	322	282	240	196	177	158	97	78	42	11						Flow rate Q [m ³ /h]
230/4 C7	540	524	509	483	453	427	396	355	318	280	258	238	180	165	126	87	71	54	26	15		
300/4 C7																						

Technical Data

Type UAK/UFK	Voltage (50 Hz) Volt	Max. Motor Rating (kW)		S3-% Operation Emerg Motor	Max. Current Ampere	RPM min ⁻¹	Cable (10 m) H07RN-F-	Fuse min.	Discharge branch PN 10	Max. Solid Size (mm)	Weight ca.
		P ₁	P ₂								
230/4 C7	3/PE~400/690	19.3	17.0	35	34.1/19.8	1460	10 G 2.5	*35 A	DN 200	100	295 kg
300/4 C7	3/PE~400/690	25.5	22.65	25	45.5/26.4	1460	7 G 6+3x1	*50 A	DN 200	100	315 kg

* Value for Y/Δ-starting

Application

The centrifugal submersible sewage pumps MultiFree are suitable for handling effluent or sewage in municipal and industrial pumping stations as well as in surface water drainage applications. The smaller types are also very successfully as portable units to deal with emergency situations.

- The sewage pumps UAK are suitable for handling sewage water.
- In hazardous locations **explosion-proof sewage pumps UFK** have to be used.

MultiFree-sewage pumps are recommended for:

- effluent which contains fibrous matter prone to matting
- effluent which contains solids
- abrasive effluent
- effluent which contains trapped air or gas
- mixed water
- raw effluent
- raw sludge
- surface water
- rainwater

Technical data

Pump

Vertical, single-stage, submersible, pump case with horizontal discharge, vortex impeller and short shaft extension. This provides a longer service life for the ball bearings and the mechanical seals.

Bearings

Common shaft for pump and motor, deep groove and inclined ball bearings, grease-packed.

Seal

Silicon carbide mechanical seal independent of sense of rotation, oil chamber and artificial carbon mechanical seal or rather SiC mechanical seal (or duplex rotary shaft seal up to size 35) as secondary seal, safe to run dry.

Motor

Submersible, enclosure IP68, activation through special purpose plug or control unit, protected by winding thermostats, UFK types tested by PTB (German tech. inspection authority), type of protection Ex II 2 G Ex d IIB T4.

Materials

pump, motor case and impeller in GG grey cast iron, corrosion protected shaft (no contact with pumped liquid), flexible rubber sheathed cable

Installation

Install pump vertically with guide rail system or pump base. Flange coupling according to DIN, coupling size B or hose tail bend up to 3" possible.

Scope of supply

Pump acc. to EN 12050 with 10 m cable without plug, without pump base:

- a) as sewage pump UAK
- b) as explosion-proof sewage pump UFK



Types of operation: Up to 40°C medium temperature
 UAK/UFK Motor submerged: continuous operation S1
 UAK/UFK Motor not submerged intermittent operation S3
 (e.g. 15% = 1.5 min operation and 8.5 min pause)

- Connection alternatively in PN 6 or PN 10
- Safe to run dry
- Controllable oil chamber
- Plug type cable connection (UAK/UFK 10...-75...)
- SiC mechanical seal independent of sense of rotation
- Moisture sealed cable inlet
- Built-in motor protection



DN 65 **n = 2800 min⁻¹**

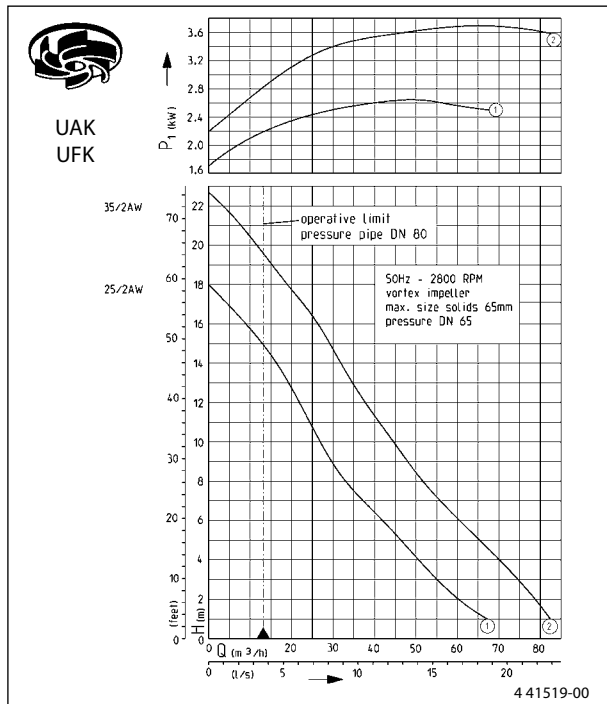

The minimum flow rate in the pressure pipe of $v = 0,7$ m/s is marked in the Q-H-diagram (operative limit).

DN 80 **n = 2800 min⁻¹**

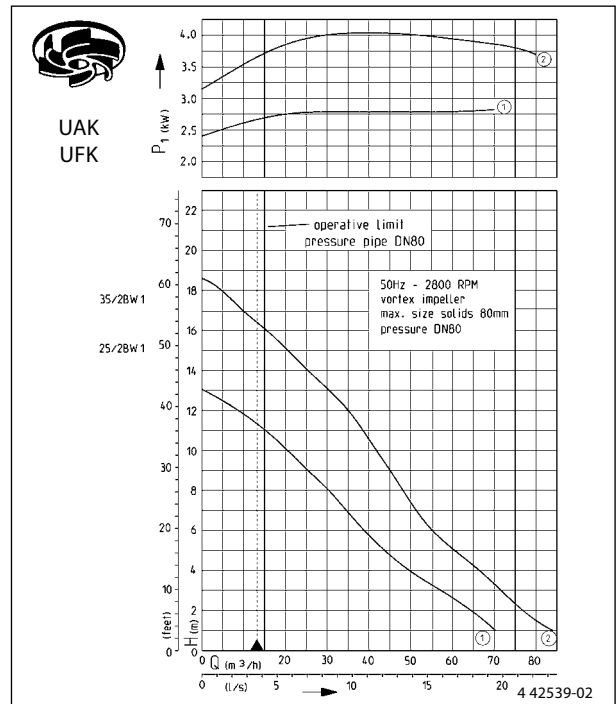

Pump performance is subject to ISO 9906 tolerances

Performance

Type UAK/UFK	1	2	3	4	5	6	7	8	9	10	12	14	16	18	20	H [m]
25/2 AW	68	61	55	51	46	41	37	33	30	27	22	16	9	Flow rate Q [m ³ /h]		
35/2 AW	82	80	76	70	65	59	56	52	48	44	38	32	26	19	11	
25/2 BW1	71	64	57	50	44	38	34	31	26	21	8	Flow rate Q [m ³ /h]				
35/2 BW1	88	77	72	67	61	55	52	48	45	42	35	25	15	5		

Technical data

Type	Voltage (50 Hz) Volt	Max. Motor Rating (kW)		S3-% Operation Emerged Motor	Max. Current Ampere	RPM min ⁻¹	Cable (10 m) H07RN-F-	Fuse min.	Discharge branch PN 6/10	Max. Solid Size (mm)	Weight ca. kg
		P ₁	P ₂								
25/2 AW	3/PE~230/400	2.90	2.30	35	8.5/4.9	2835	° 6 G 1.5	10 A	DN 65	65	43 kg
35/2 AW	3/PE~230/400	4.05	3.34	35	12.3/7.1	2884	° 6 G 1.5	10 A	DN 65	65	46 kg
25/2 BW1	3/PE~230/400	3.00	2.37	30	8.7/5.0	2828	° 6 G 1.5	10 A	DN 80	80	46 kg
35/2 BW1	3/PE~230/400	4.40	3.60	30	13.1/7.6	2878	° 6 G 1.5	10 A	DN 80	80	49 kg

° plug-in

DN 80 **n = 1400 min⁻¹**

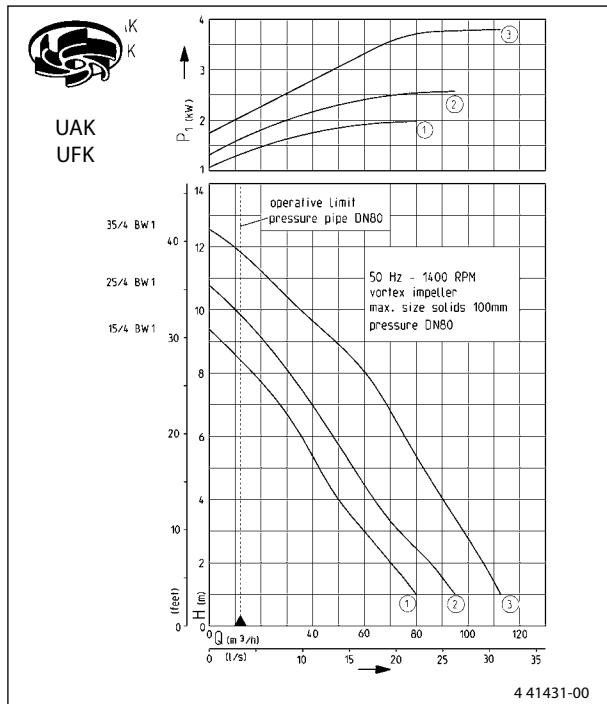

The minimum flow rate in the pressure pipe of $v = 0,7$ m/s is marked in the Q-H-diagram (operative limit). Pump performance is subject to ISO 9906 tolerances

DN 100 **n = 1400 min⁻¹**

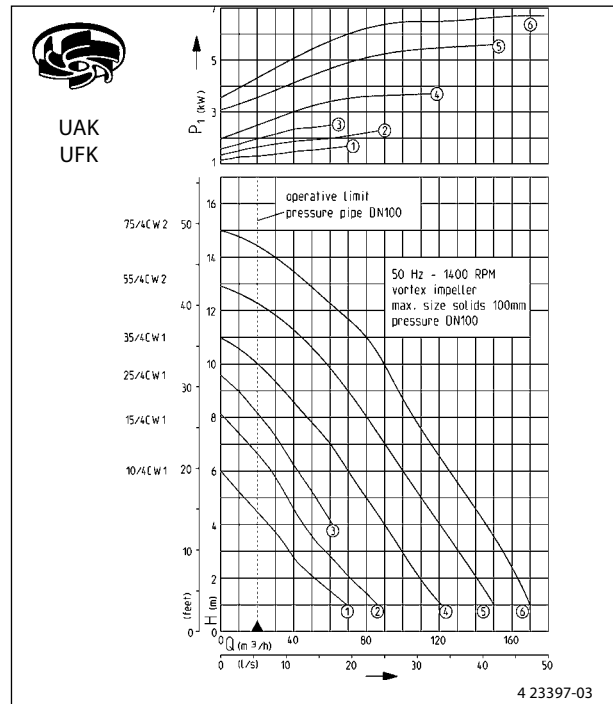

Pump performance is subject to ISO 9906 tolerances

Performance

Typen UAK/UFK	1	2	3	4	5	6	7	8	9	10	11	12	15	H [m]	
15/4 BW1	80	70	60	50	42	35	27	18	5						Flow rate Q [m ³ /h]
25/4 BW1	95	85	74	64	55	47	40	32	21	9					
35/4 BW1	115	107	98	90	82	75	68	59	49	35	23	10			
Type UAK/UFK	1	2	3	4	5	6	7	8	9	10	11	13	15	H [m]	
10/4 CW1	68	51	37	26	15									Flow rate Q [m ³ /h]	
15/4 CW1	87	71	57	46	37	28	17								
25/4 CW1				61	53	42	32	23							
35/4 CW1	122	112	100	90	81	71	60	48	35	20	3				
55/4 CW2	150	136	123	109	98	87	78	69	60	51	41				
75/4 CW2	168	158	146	135	124	115	106	97	88	79	69	47	13		

Technical Data

Type UAK/UFK	Voltage (50 Hz) Volt	Max. Motor Rating (kW)		S3-% Operation Emerged-Motor	Max. Current Ampere	RPM min ⁻¹	Cable (10 m) H07RN-F-	Fuse min.	Discharge branche PN 6/10	Max. Solid Size (mm)	Weight ca. kg
		P ₁	P ₂								
15/4 BW1	3/PE~230/400	2.20	1.70	35	7.0/4.0	1405	° 6 G 1.5	10 A	DN 80	80	47 kg
25/4 BW1	3/PE~230/400	2.80	2.10	25	8.2/4.7	1372	° 6 G 1.5	10 A	DN 80	80	47 kg
35/4 BW1	3/PE~230/400	4.20	3.20	20	13.0/7.8	1404	° 6 G 1.5	10 A	DN 80	80	51 kg
10/4 CW1	3/PE~230/400	1.80	1.40	40	5.9/3.4	1426	° 6 G 1.5	10 A	DN 100	100	49 kg
15/4 CW1	3/PE~230/400	2.40	1.90	30	7.3/4.2	1395	° 6 G 1.5	10 A	DN 100	100	49 kg
25/4 CW1	3/PE~230/400	2.70	2.04	25	7.9/4.6	1376	° 6 G 1.5	10 A	DN 100	100	49 kg
35/4 CW1	3/PE~230/400	4.20	3.20	20	13.0/7.8	1404	° 6 G 1.5	10 A	DN 100	100	53 kg
55/4 CW2	3/PE~400/690	5.80	4.65	20	10.2/5.9	1430	° 10 G 2.5	*16 A	DN 100	100	113 kg
75/4 CW2	3/PE~400/690	7.20	5.90	25	12.8/7.4	1432	° 10 G 2.5	*20 A	DN 100	100	117 kg

° plug-in

* Value for Y/Δ-starting

Accessories MultiStream/MultiFree

Example of installation GR

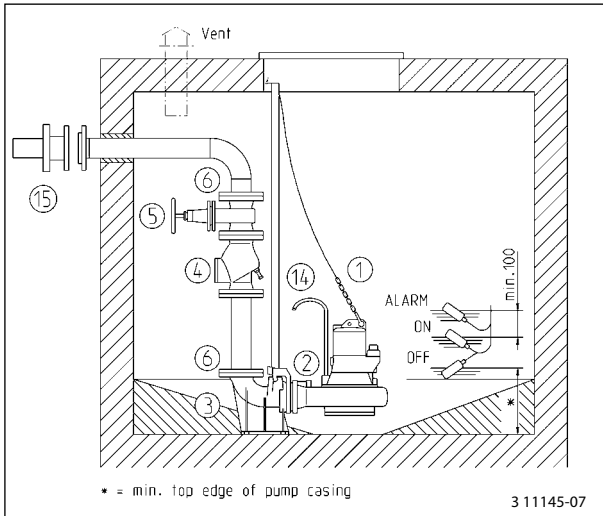

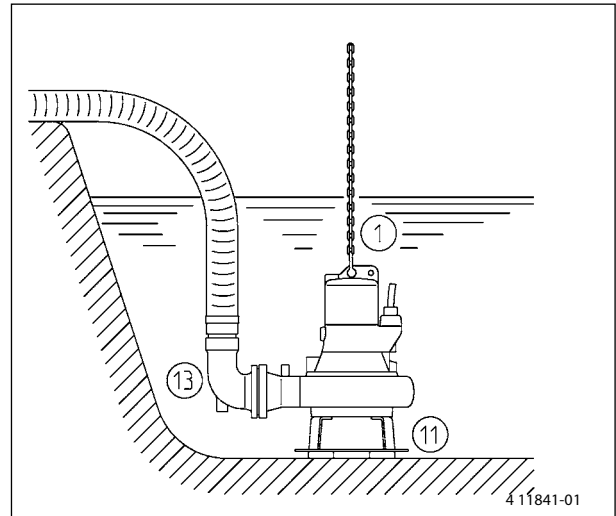

Example of installation ST



Accessories

Selection acc. to the size of casing, e.g. UAK 35/4 B4

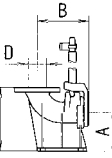
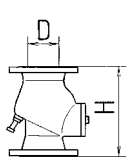
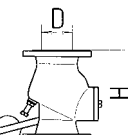
Description	Dimensions	Type	Code No.	MultiStream-Pumps							MultiFree-P.											
				A1	A2	B1	B2	B3	B4	B5	B6	C1	C2	C3	C4	C5	C6	C7	AW	BW1	CW1	CW2
 1 Chain DIN 766 carrying capacity 5 x 18.5, 2 rings 5 x 18,5, 2 rings 7 x 22,0, 2 rings Stain.1.4401, 4 x 16,0, 5 rings, 1 shackle, Stain.1.4401, 4 x 16,0, 8 rings, 2 shackles, Stain.1.4401, 6 x 18,5, 2 rings, 2 shackles, Hoist (not for 4 mm stainless steel chains)																						
			2.5 m 320 kg	JP 19189	●	●	●	●	●	●	●							●	●	●		
			5.0 m 320 kg	JP00423	●	●	●	●	●	●	●							●	●	●		
			5.0 m 630 kg	JP00416							●	●	●	●	●	●	●					●
			2.5 m 200 kg	JP 23986	●	●	●	●	●	●	●								●	●	●	
			5.0 m 200 kg	JP 24934	●	●	●	●	●	●	●								●	●	●	
		5.0 m 400 kg	JP 23989	●	●	●	●	●	●	●	●	●	●	●	●	●	●					●
		350 kg	JP 21394	●	●	●	●	●	●	●	●	●	●	●	●	●	●	●	●	●	●	●
 2 Seal leak control																						
			DKG	JP 00252	●	●	●	●	●	●	●	●	●	●	●	●	●	●	●	●	●	●
		DKG Ex	JP 00249	●	●	●	●	●	●	●	●	●	●	●	●	●	●	●	●	●	●	●
 3 Guide rail system PN 10 (incl. accessories) A B H D DN																						
	170	226	280	80	GR 65	JP 00494	●	●													●	
	170	229	280	80	GR 80	JP 00495			●	●	●	●	●	●	●	●	●				●	
	200	254	310	100	GR 100	JP 00496															●	
	235	254	345	100	GR 101	JP 21037						●										●
	260	332	435	150	GR 151	JP 00693						●										●
	260	332	435	150	GR 151 S	JP 09731							●	●	●							
	305	410	535	200	GR 200 S	JP 42275																●
	 4 Ball check valve* Flange PN 10. DIN 3202. DIN EN 12050-4 (Dimensions see swing-type check valve) K 80 JP 09842  Swing-type check valve* Flange PN 10. DIN 3202. DIN EN 12050-4 (except for R 150 G) H D DN PN without counter weight																					
260		80	4		R 80	JP 00706	●	●	●	●	●	●	●	●	●	●	●	●	●	●	●	
300		100	4		R 101	JP 00325	○	○	○	○	○	○	○	○	○	○	○	○	○	○	○	○
260		80	4		R 80 G	JP 00707	●	●	●	●	●	●	●	●	●	●	●	●	●	●	●	
300		100	4		R 100 G	JP 00324	○	○	○	○	○	○	○	○	○	○	○	○	○	○	○	
400		150	10		R 150 G	JP 00345																●



* c/w screws and gaskets

● Main

○ Alternativ proposal

Accessories

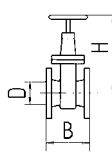
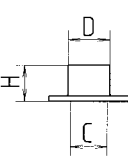
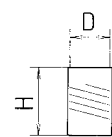
Selection acc. to the size of casing, e.g. UAK 35/4 B4

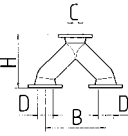
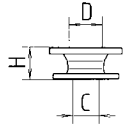
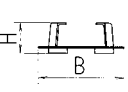
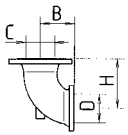
Description	Dimensions	Type	Code No.	MultiStream-Pumps														MultiFree-P.				
				A1	A2	B1	B2	B3	B4	B5	B6	C1	C2	C3	C4	C5	C6	C7	AW	BW1	CW1	CW2
 <p>5 Sluice valve* PN 10 DIN for EN 1171</p>	H B D																					
		DN																				
	315 180 80		DN 80	JP 00639	●	●	●	●	●	●								●	●			
	345 190 100		DN 100	JP 00329	○	○	○	○	○	○	○	○						○	○	●	●	
430 210 150		DN 150	JP 00328									●	●	●								
 <p>6 Spigot flange for steel pipe*</p>	H D C	Flange																				
		DN	PN 10																			
	75 90 80		A 080	JP 00686	●	●	●	●	●	●								●	●			
	76 114 80		B 080/100	JP 09821	○	○	○	○	○	○								○	○			
	100 114 100		C 100	JP 00688							●	●						●	●		●	●
147 165 150		C 150	JP 00703							○	○	●	●	●	○	○				○	○	
<p>Spigot flange for plastic pipe* F-KS</p>	H D C	Flange																				
		DN	PN 10																			
	75 90 80			JP 00686	●	●	●	●	●	●								●	●			
	85 110 80			JP 00687	○	○	○	○	○	○								○	○			
	153 110 100			JP 08673							●	●	○					●	●		●	●
173 160 150			JP 08675							○	○	●	●	●	○	○				○	○	
 <p>7 Elastic connection</p>	DN H PN D																					
	steel + plastic	80 200 4 90	DN 80	JP 05450	●	●	●	●	●	●								●	●			
	steel	100 200 4 114	DN 100	JP 16348	○	○	○	○	○	○	●	●	○					○	○	●	●	
		150 350 4 165	DN 150	JP 00704									●	●	●							
	plastic	100 200 4 110	DN 100	JP 21043	○	○	○	○	○	○	○	○	○	○	○	○	○		○	○	●	●
150 350 4 160	DN 150	JP 21044										●	●	●								
 <p>8 Hose band clamp</p>																						
					3" (DN 80)	JP 03574	●	●	●	●	●							●	●			
					4" (DN 100)	JP 03575	○	○	○	○	○	○	○					○	○	●	●	
6" (DN 150)	JP 00705											●	●	●								
 <p>9 Flanged Y-pipe* PN 10</p>	H B C D	DN																				
	355 390 100 80	80/100/ 80	JP 00448	●	●	●	●	●	●									●	●			
	355 390 100 100	100/100/100	JP 00458	○	○	○	○	○	○	○	○							○	○	●	●	
	355 390 150 100	100/150/100	JP 00449									○								○		
	355 480 100 80	80/100/ 80	JP 00202	●	●	●	●	●	●									●	●			
	355 480 100 100	100/100/100	JP 00203	○	○	○	○	○	○	○	○	○						○	○	●	○	
	355 480 150 100	100/150/100	JP 00204									○	○							○	●	
	355 480 150 150	150/150/150	JP 00521									○	○	●						○	○	
 <p>10 Reducing adapter* to PN 10</p>	H C D																					
		DN DN																				
	100 80 100		DN 80/100	JP 00498	●	●	●	●	●	●								●	●			
200 100 150		DN 100/150	JP 00510							●	●						●	●		●	●	
 <p>11 Pump pedestal*</p>	H B																					
	76 245		A 170	JP 00681	●																	
	76 295		A 220	JP 00682		●												●				
	115 280		B 170	JP 00683			●															
	115 330		B 220	JP 00684				●	●	●									●			
	145 345		C 220	JP 11453																	●	
	145 390		C 275	JP 00685							●	●	●					●				
	145 565		C 325	JP 00701										●								●
145 145 650		C 410	JP 00702														●	●	●			
 <p>12 Flanged socket*</p>	H B C (PN10) D (PN6)																					
		DN DN																				
	130 75 80 65		A 80	JP 00577	●	●													●			
	150 100 80 80		B 80	JP 00578			●	●	●	●	●									●		
	175 120 100 100		C 100	JP 00579								●	●								●	●
250 175 150 150		C 150	JP 00591															●	●	●	●	

Inner support sleeve is necessary (on request) for PE-HD pipe. ● Main ○ Alternativ proposal □ depended on the motor output
 * c/w screws and gaskets

Dimensions guide rail system MultiStream (mm)

For permanent stations, particularly for installations which are subject to routine official safety inspections, this is a neat and low-maintenance solution.

- Easy maintenance - independent of the sump depth.
- No need to release old connections, no troublesome re-aligning of screw connections needed when putting the pump back into operation.
- No need to empty the sump with another pump in the case of failure or fault in the plant.
- Save time and money on maintenance.

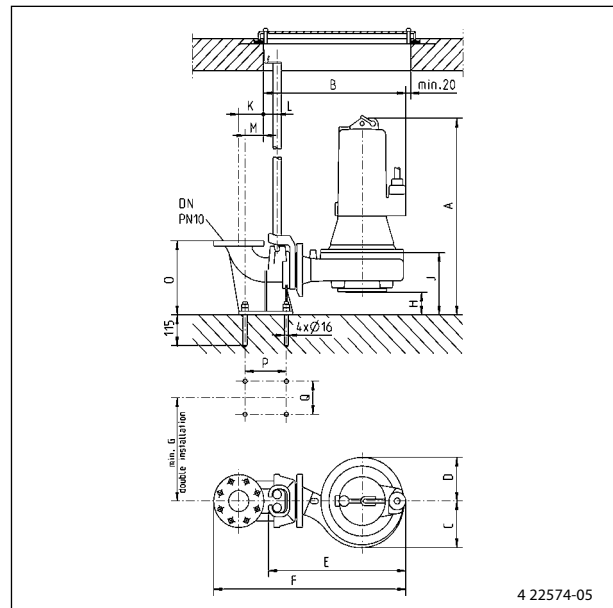

MultiStream

Type UAK/UFK	GR	DN	A	B	C	D	E	F	G	H	J	K	L	M	N	O	P	Q
10/2 A1	65	80	510	460	110	105	435	660	390	108	213	100	55	74	1"	280	165	125
15/2 A1	65	80	510	460	110	105	435	660	390	108	213	100	55	74	1"	280	165	125
25/2 A2	65	80	510	480	130	125	455	680	390	108	220	100	55	74	1"	280	165	125
35/2 A2	65	80	545	480	130	125	455	680	390	108	220	100	55	74	1"	280	165	125
25/2 B1	80	80	520	475	130	110	455	675	390	95	225	100	55	74	1"	280	165	125
35/2 B2	80	80	555	495	145	125	475	695	390	92	225	100	55	74	1"	280	165	125
55/2 B2	80	80	680	525	145	125	510	725	390	92	225	100	55	74	1"	280	165	125
75/2 B5	80	80	685	565	180	165	550	765	390	85	235	100	55	74	1"	280	165	125
100/2 B5	80	80	745	565	180	165	550	765	390	85	235	100	55	74	1"	280	165	125
200/2 B6	101	100	910	680	235	190	660	900	480	155	315	110	55	82	1"	345	175	385
300/2 B6	101	100	1000	680	235	190	660	900	480	155	315	110	55	82	1"	345	175	385
10/4 B1	80	80	520	475	130	110	455	675	390	95	225	100	55	74	1"	280	165	125
15/4 B3	80	80	520	490	145	125	470	690	390	95	225	100	55	74	1"	280	165	125
25/4 B4	80	80	520	570	190	160	545	770	390	85	225	100	55	74	1"	280	165	125
35/4 B4	80	80	555	570	190	160	545	770	390	85	225	100	55	74	1"	280	165	125
55/4 B6	101	100	765	670	235	190	650	890	480	155	315	110	55	82	1"	345	175	385
75/4 B6	101	100	765	670	235	190	650	890	480	155	315	110	55	82	1"	345	175	385
25/4 C1	100	100	565	570	185	160	550	790	390	95	270	110	55	82	1"	310	175	150
35/4 C1	100	100	600	570	185	160	550	790	390	95	270	110	55	82	1"	310	175	150
55/4 C5	101	100	765	645	230	180	625	865	480	125	315	110	55	82	1"	345	175	385
75/4 C5	101	100	765	645	230	180	625	865	480	125	315	110	55	82	1"	345	175	385
100/4 C5	101	100	825	645	230	180	625	865	480	125	315	110	55	82	1"	345	175	385
150/4 C6	101	100	910	755	290	250	735	975	580	105	315	110	55	82	1"	345	175	385
230/4 C6	101	100	1000	755	290	250	735	975	580	105	315	110	55	82	1"	345	175	385
300/4 C6	101	100	1000	755	290	250	735	975	580	105	315	110	55	82	1"	345	175	385
76/4 C5	101	100	765	645	230	180	625	865	480	125	315	110	55	82	1"	345	175	385
151/4 C6	101	100	910	755	290	250	735	975	580	105	315	110	55	82	1"	345	175	385
231/4 C6	101	100	1000	755	290	250	735	975	580	105	315	110	55	82	1"	345	175	385
55/4 C2	151S	150	790	770	260	200	740	1055	480	150	340	145	80	122	1½"	435	260	385
75/4 C2	151S	150	790	770	260	200	740	1055	480	150	340	145	80	122	1½"	435	260	385
100/4 C2	151S	150	850	770	260	200	740	1055	480	150	340	145	80	122	1½"	435	260	385
150/4 C3	151	150	935	885	325	260	855	1175	630	130	340	145	80	122	1½"	435	260	385
230/4 C3	151	150	1025	885	325	260	855	1175	630	130	340	145	80	122	1½"	435	260	385
300/4 C4	151	150	1025	885	325	260	855	1175	630	130	340	145	80	122	1½"	435	260	385
151/4 C3	151	150	935	885	325	260	855	1175	630	130	340	145	80	122	1½"	435	260	385
231/4 C4	151	150	1025	885	325	260	855	1175	630	130	340	145	80	122	1½"	435	260	385
230/4 C7	200S	200	1070	935	325	260	905	1305	630	175	385	200	80	193	1½"	535	350	400
300/4 C7	200S	200	1070	935	325	260	905	1305	630	175	385	200	80	193	1½"	535	350	400

Dimensions pump base MultiStream (mm)

For transportable application and mobile use on various sites, a pump with base and hose connection is suitable.

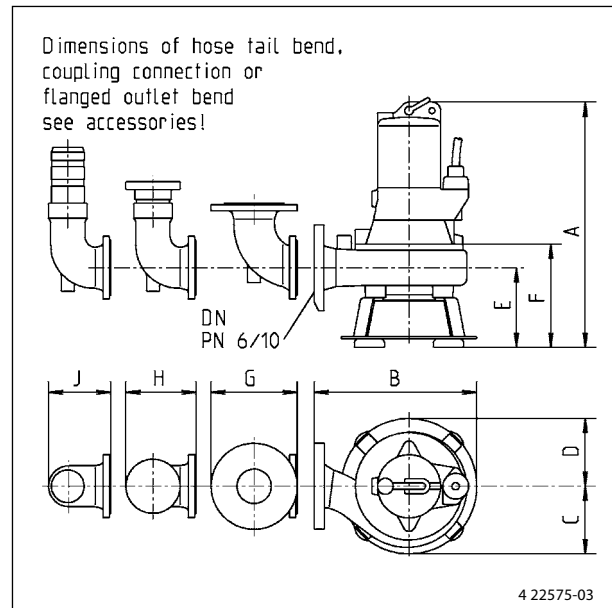
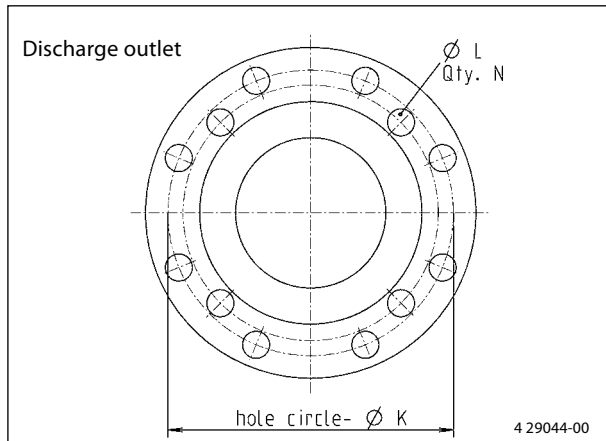

MultiStream

Type UAK/UFK	DN	A	B	C	D	E	F	G	H	J	K	L	N
10/2 A1	65	475	325	110	105	135	175	175	140	120	130/145	14/18	4
15/2 A1	65	475	325	110	105	135	175	175	140	120	130/145	14/18	4
25/2 A2	65	475	345	135	135	135	185	175	140	120	130/145	14/18	4
35/2 A2	65	510	345	135	135	135	185	175	140	120	130/145	14/18	4
25/2 B1	80	530	340	135	135	185	240	200	165	145	150/160	18	4/8
35/2 B2	80	570	380	145	135	185	240	200	165	145	150/160	18	4/8
55/2 B2	80	700	395	145	135	185	240	200	165	145	150/160	18	4/8
75/2 B5	80	725	460	195	195	215	280	200	165	145	150/160	18	4/8
100/2 B5	80	785	460	195	195	215	280	200	165	145	150/160	18	4/8
200/2 B6	100	885	535	235	195	210	290	230	-	-	170/180	18	4/8
300/2 B6	100	975	535	235	195	210	290	230	-	-	170/180	18	4/8
10/4 B1	80	530	340	135	135	185	240	200	165	145	150/160	18	4/8
15/4 B3	80	535	380	160	160	185	240	200	165	145	150/160	18	4/8
25/4 B4	80	535	440	190	160	185	240	200	165	145	150/160	18	4/8
35/4 B4	80	570	440	190	160	185	240	200	165	145	150/160	18	4/8
55/4 B6	100	740	520	235	195	210	290	230	-	-	170/180	18	4/8
75/4 B6	100	740	520	235	195	210	290	230	-	-	170/180	18	4/8
25/4 C1	100	600	450	195	195	235	305	230	-	-	170/180	18	4/8
35/4 C1	100	635	450	195	195	235	305	230	-	-	170/180	18	4/8
55/4 C5	100	775	480	230	195	240	320	230	-	-	170/180	18	4/8
75/4 C5	100	775	480	230	195	240	320	230	-	-	170/180	18	4/8
100/4 C5	100	835	480	230	195	240	320	230	-	-	170/180	18	4/8
150/4 C6	100	925	610	290	250	250	330	230	-	-	170/180	18	4/8
230/4 C6	100	1015	610	290	250	250	330	230	-	-	170/180	18	4/8
300/4 C6	100	1015	610	290	250	250	330	230	-	-	170/180	18	4/8
76/4 C5	100	775	480	230	195	240	320	230	-	-	170/180	18	4/8
151/4 C6	100	925	610	290	250	250	330	230	-	-	170/180	18	4/8
231/4 C6	100	1015	610	290	250	250	330	230	-	-	170/180	18	4/8
55/4 C2	150	770	580	260	215	240	320	320	-	-	225/240	18/22	8
75/4 C2	150	770	580	260	215	240	320	320	-	-	225/240	18/22	8
100/4 C2	150	830	580	260	215	240	320	320	-	-	225/240	18/22	8
150/4 C3	150	925	695	325	260	250	330	320	-	-	225/240	18/22	8
230/4 C3	150	1015	695	325	260	250	330	320	-	-	225/240	18/22	8
300/4 C4	150	1015	695	325	260	250	330	320	-	-	225/240	18/22	8
151/4 C3	150	925	695	325	260	250	330	320	-	-	225/240	18/22	8
231/4 C4	150	1015	695	325	260	250	330	320	-	-	225/240	18/22	8
230/4 C7	200	1015	725	325	260	250	330	-	-	-	295	22	8
300/4 C7	200	1015	725	325	260	250	330	-	-	-	295	22	8

Dimensions guide rail system MultiFree (mm)

For permanent stations, particularly for installations which are subject to routine official safety inspections, this is a neat and low-maintenance solution.

- Easy maintenance - independent of the sump depth.
- No need to release old connections, no troublesome re-aligning of screw connections needed when putting the pump back into operation.
- No need to empty the sump with another pump in the case of failure or fault in the plant.
- Save time and money on maintenance.

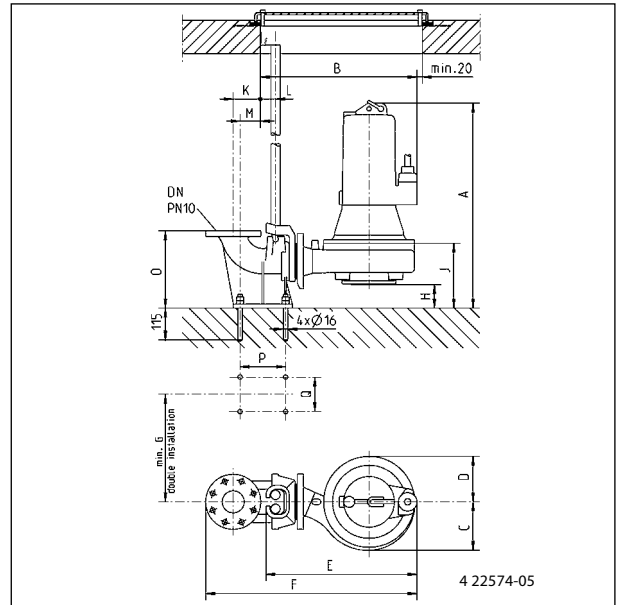

MultiFree

Type UAK/UFK	GR	DN	A	B	C	D	E	F	G	H	J	K	L	M	N	O	P	Q
25/2 AW	65	80	520	490	130	130	470	690	390	115	220	100	55	74	1"	280	165	125
35/2 AW	65	80	555	490	130	130	470	690	390	115	220	100	55	74	1"	280	165	125
25/2 BW1	80	80	535	490	140	140	485	705	390	85	235	100	55	74	1"	280	165	125
35/2 BW1	80	80	570	490	140	140	485	705	390	85	235	100	55	74	1"	280	165	125
15/4 BW1	80	80	530	505	140	140	485	705	390	85	235	100	55	74	1"	280	165	125
25/4 BW1	80	80	535	505	140	140	485	705	390	85	235	100	55	74	1"	280	165	125
35/4 BW1	80	80	570	505	140	140	485	705	390	85	235	100	55	74	1"	280	165	125
10/4 CW1	100	100	565	540	140	140	520	760	390	120	270	110	55	82	1"	310	175	150
15/4 CW1	100	100	565	540	140	140	520	760	390	120	270	110	55	82	1"	310	175	150
25/4 CW1	100	100	565	540	140	140	520	760	390	120	270	110	55	82	1"	310	175	150
35/4 CW1	100	100	600	540	140	140	520	760	390	120	270	110	55	82	1"	310	175	150
55/4 CW2	101	100	775	635	195	195	620	860	480	135	330	110	55	82	1"	345	175	385
75/4 CW2	101	100	775	635	195	195	620	860	480	135	330	110	55	82	1"	345	175	385

Dimensions pump base MultiFree (mm)

For transportable application and mobile use on various sites, a pump with base and hose connection is suitable.

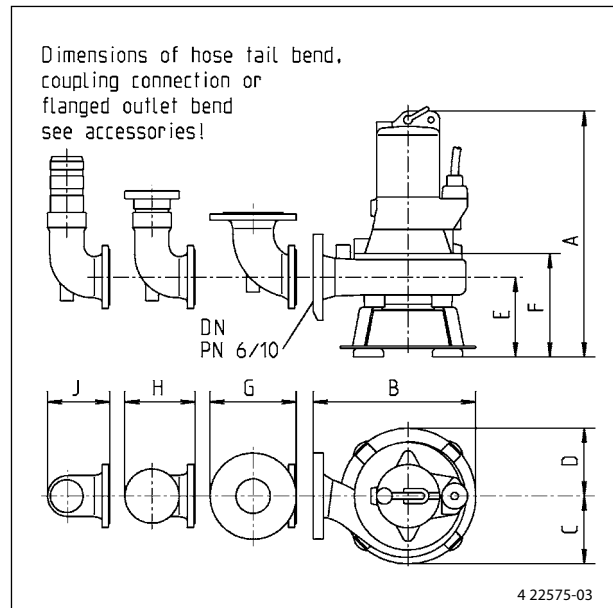
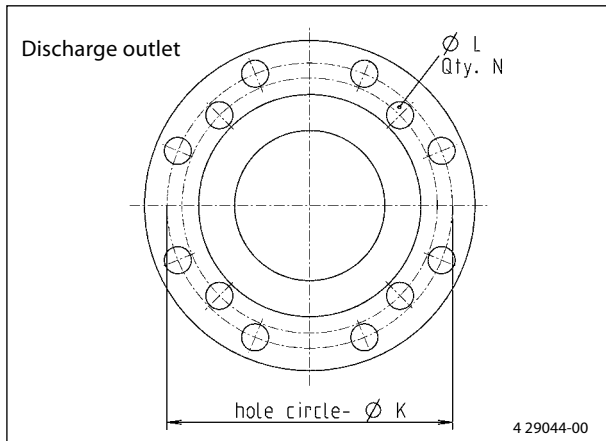

MultiFree

Type UAK/UFK	DN	A	B	C	D	E	F	G	H	J	K	L	N
25/2 AW	65	500	360	135	135	155	215	175	140	120	130/145	14/18	4
35/2 AW	65	535	360	135	135	155	215	175	140	120	130/145	14/18	4
25/2 BW1	80	550	375	140	140	205	265	200	165	145	150/160	18	4/8
35/2 BW1	80	585	375	140	140	205	265	200	165	145	150/160	18	4/8
15/4 BW1	80	550	375	140	140	205	265	200	165	145	150/160	18	4/8
25/4 BW1	80	550	375	140	140	205	265	200	165	145	150/160	18	4/8
35/4 BW1	80	585	375	140	140	205	265	200	165	145	150/160	18	4/8
10/4 CW1	100	585	415	165	165	220	290	230	-	-	170/180	18	4/8
15/4 CW1	100	585	415	165	165	220	290	230	-	-	170/180	18	4/8
25/4 CW1	100	585	415	165	165	220	290	230	-	-	170/180	18	4/8
35/4 CW1	100	620	415	165	165	220	290	230	-	-	170/180	18	4/8
55/4 CW2	100	785	520	215	215	245	335	230	-	-	170/180	18	4/8
75/4 CW2	100	785	520	215	215	245	335	230	-	-	170/180	18	4/8

Assignment of control units MultiStream



MultiStream Sewage pump without ex-proof		Single unit		Duplex unit		MultiStream Sewage pump with ex-proof		Single unit		Duplex unit	
Type UAK	Code No.	Control unit without float switch	Code No.	Control unit without float switch	Code No.	Type UFK	Code No.	Control unit without float switch	Code No.	Control unit without float switch	Code No.
10/2 A1	JP 09615	AD 25	JP 00310	BD 25	JP 00302	10/2 A1	JP 09628	AD 25 Ex	JP 09683	BD 25 Ex	JP 09681
15/2 A1	JP 09616	AD 25	JP 00310	BD 25	JP 00302	15/2 A1	JP 09629	AD 25 Ex	JP 09683	BD 25 Ex	JP 09681
25/2 A2	JP 09617	AD 46	JP 14353	BD 46	JP 14358	25/2 A2	JP 09630	AD 46 Ex	JP 14355	BD 46 Ex	JP 14360
35/2 A2	JP 09651	AD 610	JP 14354	BD 610	JP 14359	35/2 A2	JP 09653	AD 610 Ex	JP 14356	BD 610 Ex	JP 14361
25/2 B1	JP 09618	AD 46	JP 14353	BD 46	JP 14358	25/2 B1	JP 09631	AD 46 Ex	JP 14355	BD 46 Ex	JP 14360
35/2 B2	JP 09652	AD 610	JP 14354	BD 610	JP 14359	35/2 B2	JP 09654	AD 610 Ex	JP 14356	BD 610 Ex	JP 14361
55/2 B2	JP 09663	AS 46*	JP 14406	BS 46*	JP 14411	55/2 B2	JP 09664	AS 46*	JP 14406	BS 46*	JP 14411
75/2 B5	JP 00485	AS 610	JP 14407	BS 610	JP 14412	75/2 B5	JP 09665	AS 610	JP 14407	BS 610	JP 14412
100/2 B5	JP 09740	AS 1016	JP 14408	BS 1016	JP 14413	100/2 B5	JP 09741	AS 1016	JP 14408	BS 1016	JP 14413
200/2 B6	JP 00492	AS 1624	JP 14409	BS 1624	JP 14414	200/2 B6	JP 00472	AS 1624	JP 14409	BS 1624	JP 14414
300/2 B6	JP 00471	AS 2440	JP 14410	BS 2440	JP 14415	300/2 B6	JP 00473	AS 2440	JP 14410	BS 2440	JP 14415
10/4 B1	JP 09620	AD 25	JP 00310	BD 25	JP 00302	10/4 B1	JP 09633	AD 25 Ex	JP 09683	BD 25 Ex	JP 09681
15/4 B3	JP 09622	AD 25	JP 00310	BD 25	JP 00302	15/4 B3	JP 09635	AD 25 Ex	JP 09683	BD 25 Ex	JP 09681
25/4 B4	JP 09623	AD 46	JP 14353	BD 46	JP 14358	25/4 B4	JP 09636	AD 46 Ex	JP 14355	BD 46 Ex	JP 14360
35/4 B4	JP 09647	AD 610	JP 14354	BD 610	JP 14359	35/4 B4	JP 09649	AD 610 Ex	JP 14356	BD 610 Ex	JP 14361
55/4 B6	JP 00486	AS 610*	JP 14407	BS 610*	JP 14412	55/4 B6	JP 09666	AS 610*	JP 14407	BS 610*	JP 14412
75/4 B6	JP 00489	AS 610	JP 14407	BS 610	JP 14412	75/4 B6	JP 09667	AS 610	JP 14407	BS 610	JP 14412
25/4 C1	JP 09624	AD 46	JP 14353	BD 46	JP 14358	25/4 C1	JP 09637	AD 46 Ex	JP 14355	BD 46 Ex	JP 14360
35/4 C1	JP 09648	AD 610	JP 14354	BD 610	JP 14359	35/4 C1	JP 09650	AD 610 Ex	JP 14356	BD 610 Ex	JP 14361
55/4 C5	JP 09901	AS 610*	JP 14407	BS 610*	JP 14412	55/4 C5	JP 09902	AS 610*	JP 14407	BS 610*	JP 14412
75/4 C5	JP 09904	AS 610	JP 14407	BS 610	JP 14412	75/4 C5	JP 09905	AS 610	JP 14407	BS 610	JP 14412
100/4 C5	JP 09275	AS 1016	JP 14408	BS 1016	JP 14413	100/4 C5	JP 09276	AS 1016	JP 14408	BS 1016	JP 14413
150/4 C6	JP 09882	AS 1624	JP 14409	BS 1624	JP 14414	150/4 C6	JP 09883	AS 1624	JP 14409	BS 1624	JP 14414
230/4 C6	JP 09885	AS 1624	JP 14409	BS 1624	JP 14414	230/4 C6	JP 09886	AS 1624	JP 14409	BS 1624	JP 14414
300/4 C6	JP 09888	AS 2440	JP 14410	BS 2440	JP 14415	300/4 C6	JP 09889	AS 2440	JP 14410	BS 2440	JP 14415
151/4 C6	JP 09400	AS 1624	JP 14409	BS 1624	JP 14414	151/4 C6	JP 09401	AS 1624	JP 14409	BS 1624	JP 14414
231/4 C6	JP 09402	AS 1624	JP 14409	BS 1624	JP 14414	231/4 C6	JP 09403	AS 1624	JP 14409	BS 1624	JP 14414
151/4 C3	JP 09445	AS 1624	JP 14409	BS 1624	JP 14414	151/4 C3	JP 09446	AS 1624	JP 14409	BS 1624	JP 14414
55/4 C2	JP 00487	AS 610*	JP 14407	BS 610*	JP 14412	55/4 C2	JP 09668	AS 610*	JP 14407	BS 610*	JP 14412
75/4 C2	JP 00490	AS 610	JP 14407	BS 610	JP 14412	75/4 C2	JP 09669	AS 610	JP 14407	BS 610	JP 14412
100/4 C2	JP 09678	AS 1016	JP 14408	BS 1016	JP 14413	100/4 C2	JP 09679	AS 1016	JP 14408	BS 1016	JP 14413
150/4 C3	JP 00491	AS 1624	JP 14409	BS 1624	JP 14414	150/4 C3	JP 00474	AS 1624	JP 14409	BS 1624	JP 14414
230/4 C3	JP 00883	AS 1624	JP 14409	BS 1624	JP 14414	230/4 C3	JP 00884	AS 1624	JP 14409	BS 1624	JP 14414
300/4 C4	JP 00493	AS 2440	JP 14410	BS 2440	JP 14415	300/4 C4	JP 00475	AS 2440	JP 14410	BS 2440	JP 14415
231/4 C4	JP 09447	AS 1624	JP 14409	BS 1624	JP 14414	231/4 C4	JP 09448	AS 1624	JP 14409	BS 1624	JP 14414
76/4 C5	JP 09398	AS 610	JP 14407	BS 610	JP 14412	76/4 C5	JP 09399	AS 610	JP 14407	BS 610	JP 14412
230/4 C7	JP 09392	AS 1624	JP 14409	BS 1624	JP 14414	230/4 C7	JP 09393	AS 1624	JP 14409	BS 1624	JP 14414
300/4 C7	JP 09394	AS 2440	JP 14410	BS 2440	JP 14415	300/4 C7	JP 09395	AS 2440	JP 14410	BS 2440	JP 14415

*In connection with UAK/UFK 55/... a controll unit with direct start is required.

For UFK pumps please consider the dry run protection JP 41463.

Additional requirements, see technical data control units

Assignment of control units MultiFree

MultiFree Sewage pump without ex-proof		Single unit		Duplex unit		MultiFree Sewage pump with ex-proof		Single unit		Duplex unit	
Type UAK	Code No.	Control unit without float switch	Code No.	Control unit without float switch	Code No.	Type UFK	Code No.	Control unit without float switch	Code No.	Control unit without float switch	Code No.
25/2 AW	JP 09149	AD 46	JP 14353	BD 46	JP 14358	25/2 AW	JP 09150	AD 46 Ex	JP 14355	BD 46 Ex	JP 14360
35/2 AW	JP 09151	AD 610	JP 14354	BD 610	JP 14359	35/2 AW	JP 09152	AD 610 Ex	JP 14356	BD 610 Ex	JP 14361
25/2 BW1	JP 09498	AD 46	JP 14353	BD 46	JP 14358	25/2 BW1	JP 09499	AD 46 Ex	JP 14355	BD 46 Ex	JP 14360
35/2 BW1	JP 09500	AD 610	JP 14354	BD 610	JP 14359	35/2 BW1	JP 09501	AD 610 Ex	JP 14356	BD 610 Ex	JP 14361
15/4 BW1	JP 09455	AD 46	JP 14353	BD 46	JP 14358	15/4 BW1	JP 09458	AD 46 Ex	JP 14355	BD 46 Ex	JP 14360
25/4 BW1	JP 09456	AD 46	JP 14353	BD 46	JP 14358	25/4 BW1	JP 09459	AD 46 Ex	JP 14355	BD 46 Ex	JP 14360
35/4 BW1	JP 09457	AD 610	JP 14354	BD 610	JP 14359	35/4 BW1	JP 09460	AD 610 Ex	JP 14356	BD 610 Ex	JP 14361
10/4 CW1	JP 09610	AD 25	JP 00310	BD 25	JP 00302	10/4 CW1	JP 09609	AD 25 Ex	JP 09683	BD 25 Ex	JP 09681
15/4 CW1	JP 09612	AD 46	JP 14353	BD 46	JP 14358	15/4 CW1	JP 09611	AD 46 Ex	JP 14355	BD 46 Ex	JP 14360
25/4 CW1	JP 09655	AD 46	JP 14353	BD 46	JP 14358	25/4 CW1	JP 09656	AD 46 Ex	JP 14355	BD 46 Ex	JP 14360
35/4 CW1	JP 09858	AD 610	JP 14354	BD 610	JP 14359	35/4 CW1	JP 09859	AD 610 Ex	JP 14356	BD 610 Ex	JP 14361
55/4 CW2	JP 09702	AS 610*	JP 14407	BS 610*	JP 14412	55/4 CW2	JP 09704	AS 610*	JP 14407	BS 610*	JP 14412
75/4 CW2	JP 09703	AS 610	JP 14407	BS 610	JP 14412	75/4 CW2	JP 09705	AS 610	JP 14407	BS 610	JP 14412

* In connection with UAK/UFK 55/... a control unit with direct start is required.

For UFK pumps please consider the dry run protection JP 41463.

Additional requirements, see technical data control units

Flushing tube

Especially in connection with sumps designed by customers, where the shape of the collecting tank is not always ideal, a flushing tube offers the facility to reduce deposits at the sump wall and the formation of surface scums. The flushing tube is mounted instead of the ventilation screw. The special arrangement prevents the flushing tube from blocking and increases the operational reliability.



Seal leak detector

The seal leak detector is used to monitor the sealing of the oil chamber between the motor and the hydraulic section of the pumps in the series US / UB and UAK/UFK. If ingress of water into the oil chamber occurs an integrated buzzer is activated.



Discharge connection combi. PN 6 / PN 10

Thanks to the discharge connection combination PN 6 / PN 10 on all MultiStream-und MultiFree sewage pumps an universal connection to existing pipe systems is very simple. If the existing connection does not comply with the standard dimensions of DIN 1092, connection adapters for several installation situations can be obtained on request.



Nominal diameter	Hole centre line diameter-Ø		Number of bolts		Bolt size	
	PN 6	PN 10	PN 6	PN 10	PN 6	PN 10
DN 65	130	145	4	4	M 12	M 16
DN 80	150	160	4	8	M 16	M 16
DN 100	170	180	4	8	M 16	M 16
DN 150	225	240	8	8	M 16	M 20
DN 200	-	295	-	8	-	M 20

Adjustable axial gap (MultiStream)

In order to ensure optimum efficiency of a pump with channel type hydraulics over a long running period, our pumps have the possibility of adjusting the gap between the impeller and the wear ring or spiral housing by turning a central screw and thereby achieve the optimum setting. This adjustment can be carried out during a normal maintenance operation. It brings the additional advantage of a significant reduction in the possibility of a blockage occurring. Should, nevertheless, solid particles become deposited in the gap, the grooves located in the axial gap area facilitate these being transported away and reduce even further the risk of blockage.



Ceramic anti-wear coating

Channel type impellers have a larger contact area with the medium being pumped than vortex impellers. This means that they are more exposed to wear caused by abrasive liquids. An optimum coating with liquid ceramic can protect the impeller over a long period of time.

In addition a free solids passage of up to 100 mm is a further assurance of blockage free pumping.



Moisture sealed cable inlet

To protect the motor casing from water intake through the power cable the separate cores are bared and spilled with a special resin. Only this expensive method guarantees a lasting moisture consistency.

