

US 75-US 155

SUBMERSIBLE DRAINAGE PUMPS

- 50 mm free passage
- Run dry protection
- Controllable oil chamber
- SiC mechanical seal
- independent of sense of rotation
- Replaceable moisture sealed cable inlet



DESCRIPTION

The centrifugal submersible drainage pumps US 75-155 are suitable for dealing with notably contaminated water and capable of handling solids up to 50 mm particle size. With their free passage of 50 mm, these pumps are able to pump solids and fibers quickly, reliably and above all without blockage!

For easy removal of the pumps from deep sumps we recommend the use of our guide rail systems which provide ease of maintenance and inspection. A controllable oil chamber and wear-resistant special mechanical seal ensure a long service life. The integrated winding thermostats protect the motor from overload.

For automatic monitoring of the oil chamber a seal leak control can be connected.

Maximum cable length is 10 m. The US 155 DS 3-phase pump with level control has a CEE-Plug with phase inverter.

The sewage pumps are tested by the German Institute for Construction Engineering and correspond to the valid construction and test principles.

PERFORMANCE

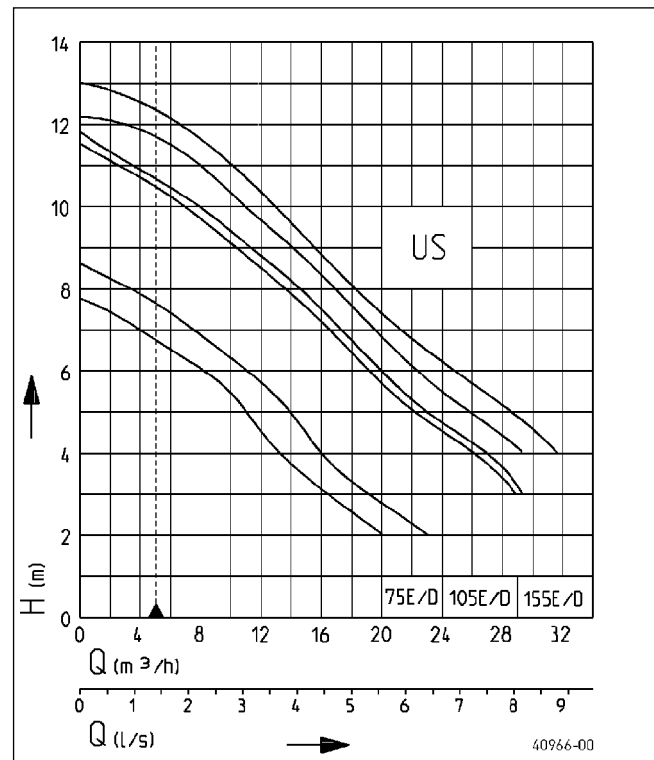

Type	Delivery head H [m]	2	3	4	5	6	7	8	9	10	11	12
US 75 E/ES	Flow rate Q [m³/h]	20	16	13	10	7	4					
US 75 D/DS		23	19	16	12	10	7	3				
US 105 E/ES			28	25	22	19	16	13	10	7	3	
US 105 D/DS			29	26	23	20	17	14	11	8	4	
US 155 E/ES				29	26	22	20	16	14	11	8	2
US 155 D/DS				31	28	25	21	19	16	13	10	

We reserve the right to change specifications without notice. Pump performance is subject to ISO 9906 tolerances

The minimum flow velocity in the pressure piping must be 0.7 m/s according to EN 12056. This data is represented in the performance curve as a limit of application.



US 75-US 155

SUBMERSIBLE DRAINAGE PUMPS

SCOPE OF SUPPLY

Pump according to EN 12050 ready for connection with 10 m cable. Foot strainer made of GRP enclosed.

US 155: Pumps without level control with free lead end. Pump with level control with CEE-Plug and phase inverter (3-phase) or safety-plug (1-phase).

MECHANICAL DATA

Pump	Vertical single-stage	Seal on medium side	SiC mechanical seal
Free passage	50 mm	Run dry protection	Yes
Bearing	Ball bearings, grease-lubricated	Impeller	Vortex impeller, GFK
Seal on motor side	Duplex rotary shaft seals	Submersible	Yes
Oil chamber	Yes	Pressure outlet	IG 2"

ELECTRICAL DATA

Power line	10m H07RN-F	Insulation class	B
Type of enclosure	IP 68	Winding thermostat	Yes

US 75-US 155

Type	Code No.	Voltage	Motor rating		Current	Wires	Motor protection	Plug	Weight
			P1	P2					
Without level control									
US 75 E	JP09406	1/N/PE~230 V	0.83 kW	0.50 kW	3.9 A	3G1,0	Integrated	Safety	13.0 kg
US 75 D	JP09404	3/PE~400 V	0.85 kW	0.60 kW	1.4 A	4G1,0	Integrated	CEE	13.1 kg
US 105 E	JP09410	1/N/PE~230 V	1.37 kW	0.98 kW	6.0 A	3G1,0	Integrated	Safety	14.5 kg
US 105 D	JP09408	3/PE~400 V	1.36 kW	1.06 kW	2.4 A	4G1,0	Integrated	CEE	15.1 kg
US 155 E	JP09388	1/N/PE~230 V	1.60 kW	1.21 kW	7.5 A	3G1,0	on request ¹	Without	16.0 kg
US 155 D	JP09390	3/PE~400 V	1.70 kW	1.41 kW	3.1 A	4G1,0	on request ¹	Without	16.5 kg
With built-in level control									
US 75 ES	JP09407	1/N/PE~230 V	0.83 kW	0.50 kW	3.9 A	3G1,0	Integrated	Safety	13.0 kg
US 75 DS	JP09405	3/PE~400 V	0.85 kW	0.60 kW	1.4 A	4G1,0	Integrated	CEE	13.2 kg
US 105 ES	JP09411	1/N/PE~230 V	1.37 kW	0.98 kW	6.0 A	3G1,0	Integrated	Safety	14.6 kg
US 105 DS	JP09409	3/PE~400 V	1.36 kW	1.06 kW	2.4 A	4G1,0	Integrated	CEE	15.2 kg
US 155 ES	JP09389	1/N/PE~230 V	1.60 kW	1.21 kW	7.5 A	3G1,0	Integrated	Safety	16.3 kg
US 155 DS	JP09391	3/PE~400 V	1.70 kW	1.41 kW	3.1 A	4G1,0	Integrated	CEE	17.2 kg

¹Protective motor plug necessary see accessory

US 75-US 155

SUBMERSIBLE DRAINAGE PUMPS

Dimensions and switching points US 75 up to US 155 (mm)

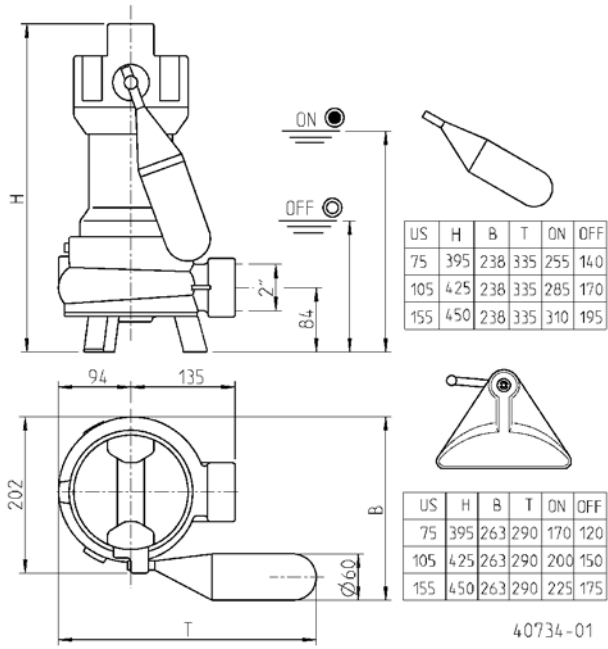

Dimensions and switching points with GR 50 S (mm)

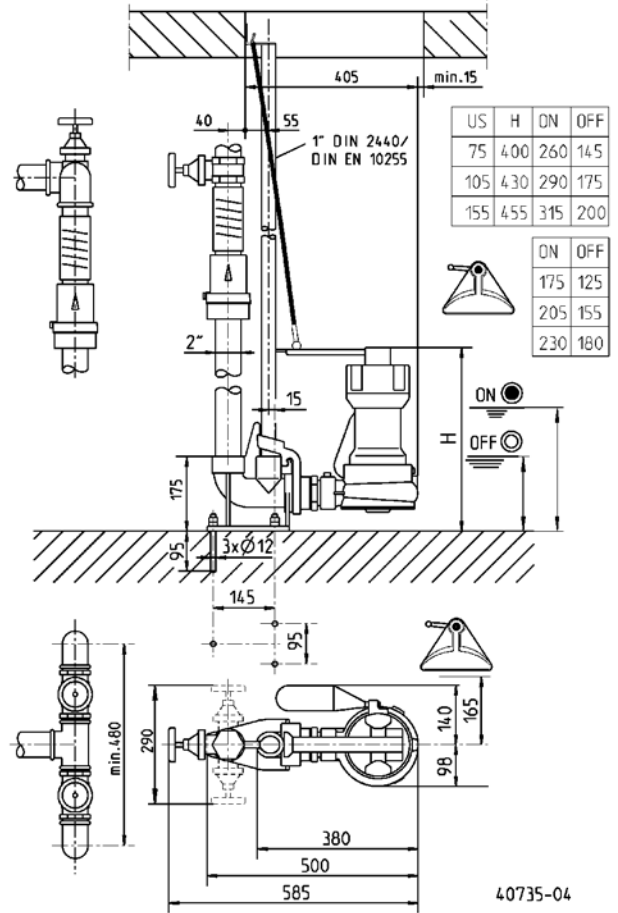

US 75-US 155

SUBMERSIBLE DRAINAGE PUMPS

Example of single installation with GR

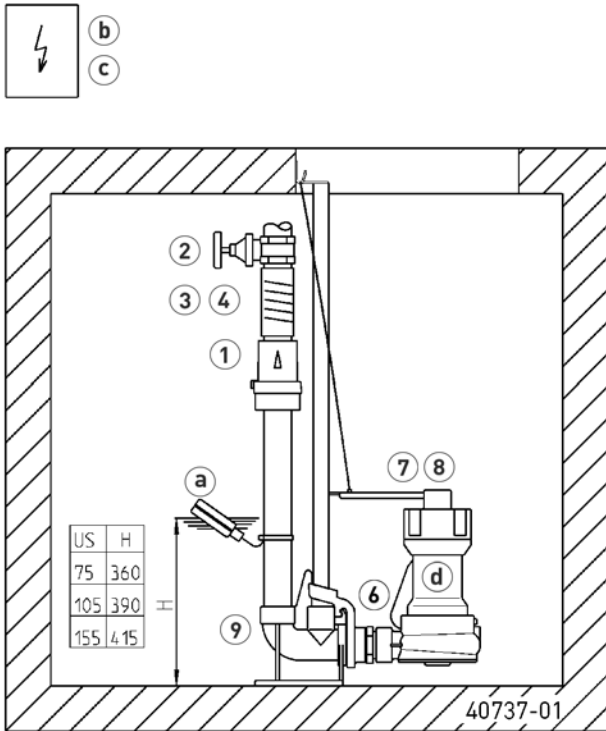

Single unit 2" with GR 50 S: sump area min. 40x65 cm
 Single unit 2" without GR: sump area min. 40x50 cm
 Duplex unit 2" with GR 50 S: sump area min. 65x70 cm
 Duplex unit 2" without GR: sump area min. 50x70 cm
 In case of installation beneath the backpressure level the pressure tube must be taken in a

Example of duplex installation

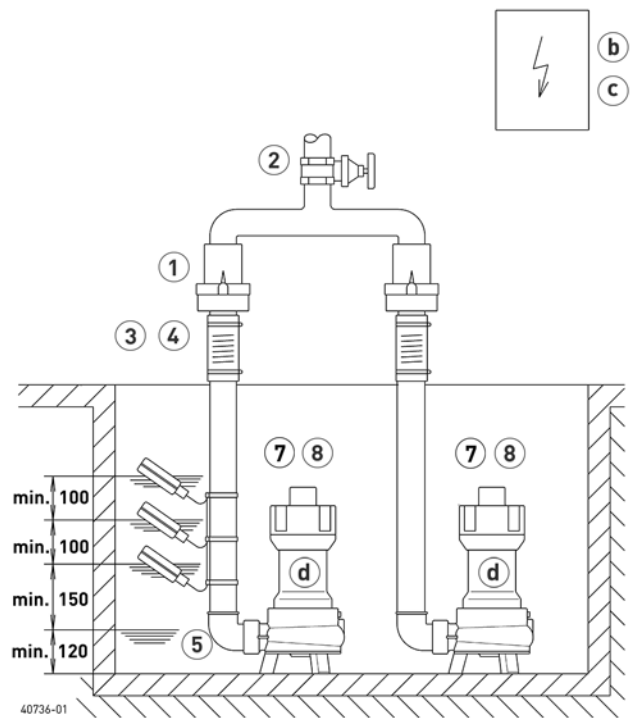

loop over the local backup level acc. to EN 12056. Besides, it must be secured with an EN 12050-4-proofed swing-type check valve. Additionally we recommend an alarm system.
 In accordance with EN 12056-4 section 5.1, it has a built-in automatic spare pump or a double attachment included, which ensures that sewage drainage is not interrupted.
 Suspend control unit in a dry room

MECHANICAL ACCESSORY

				Code No.	
	1 Swing-type check valve	R50 EN 12050-4	2" (DN 50), PN 4	150x120 (HxB)	JP00326
	Ball-type check valve	K50 EN 12050-4	2" (DN 50), PN 6	185x155 (HxB)	JP44782
	2 Stop valve		brass, 2" (DN 50), PN 16	140x70 (HxB)	JP44787
	3 Elastic connection		2" (DN 50), PN 4	150x63 (HxD)	JP44775
	4 Hose band clamp		2"		JP44764
	5 Elbow		2"		JP44771
	6 Special float		for lower switching points		JP44795



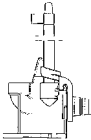

US 75-US 155

SUBMERSIBLE DRAINAGE PUMPS

MECHANICAL ACCESSORY

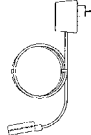
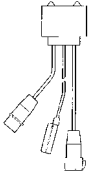
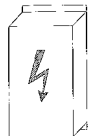
			Code No.	
	7 Chain	certified, 2.5 m, 320 kg, 5 rings (EN 818 mod.)	JP45901	
		certified, 5.0 m, 320 kg, 8 rings (EN 818 mod.)	JP45902	
		certified, 7.5 m, 320 kg, 11 rings (EN 818 mod.)	JP47365	
	8 Webbing	with shackle	JP45168	
	9 Guide rail system	GR 50	JP25593	
		Securing lever	US 75-155	JP41024
		Guide rail 1"	1500 mm	JP48937
		Guide rail 1"	2000 mm	JP48938
		Guide rail 1"	2500 mm	JP48939
		Guide rail 1"	3000 mm	JP48940
	10 Strainer base	10 mm free passage	JP45957	
Bases	stainless steel, 50 mm free passage	JP40632		



ELECTRICAL ACCESSORY

			Code No.	
	a Alarm unit	AG3	subm. ball contact switch, mains dependent, potential-free contact, 3 m cable	JP44891
		AG10	subm. ball contact switch, mains dependent, potential-free contact, 9,5 m cable	JP44892
	Washing machine stop			
		AW3	subm. ball contact switch, mains dependent, 3 m cable	JP44895
		AW0	for alarm forwarding in case of several washing machines	JP44899
	b Control for single units	Control unit NE 1	230 V, subm. ball contact switch 3.0 m	JP16710
		Control unit NE 1A	230 V, subm. ball contact switch 3.0 m, alarm	JP16714
		Control unit NE 2	230 V, subm. ball contact switch 9.5 m	JP16711
		Control unit NE 2A	230 V, subm. ball contact switch 9.5 m, alarm	JP16715
		Control unit ND 1	400 V, subm. ball contact switch 3.0 m	JP16712
		Control unit ND 1A	400 V, subm. ball contact switch 3.0 m, alarm	JP16716
		Control unit ND 3	400 V, subm. ball contact switch 9.5 m	JP16713
		Control unit ND 3A	400 V, subm. ball contact switch 9.5 m, alarm	JP16717
	Control for duplex units	Control unit BD 00 E	230 V, for pumps U3-U6, US 62-105, UV 300, 08/2 ME	JP45735
		Control unit HIGHLOGO 2-00 E	230 V	JP47996
		Control unit BD 00	400 V, for pumps U6, US 62-105, UV 300	JP45993
		Control unit HIGHLOGO 2-00	400 V	JP47997
		Control unit BD 25	400 V, for pumps US 151-155	JP45737
		Control unit HIGHLOGO 2-25	400 V	JP47998
	Level control	Subm. switch pack B	3 subm. ball contact switch with 9.5 m and fixing devices	JP16725
		Subm. switch pack BmG	3 subm. ball contact switch with 9.5 m and counterweight	JP16726
		Weight	to stabilize the subm. ball contact switch	JP44803
	Protective motor plug	Protective motor plug, 8 A	230 V, for pumps without integrated motor protection	JP44753
		CEE motor protection 2,5-4,0 A	400 V, mandatory for pumps without integrated motor protection	JP44754
	c Rechargeable battery		for mains independent alarm	JP44850

US 75-US 155

SUBMERSIBLE DRAINAGE PUMPS

ELECTRICAL ACCESSORY

			Code No.
	d Seal leak detector	DKG	JP44900
	e Smart Home	FTJP radio transmitter	JP47209